

HR 130

Low headroom version



The **HR 130** is a powerful compact rig that does not require disassembly to be transported from job to job. It is able to drill large diameters with augers and buckets and can also be equipped with several kits which allow to drill with Continuous Flight Auger, Diaphragm walls, Down the Hole Hammers and even Casing Oscillators.

The HR 130's particularly modular conception provides 170 KNm torque and it can be easily and rapidly converted depending on the drilling requirements, allowing the operator to carry out a wide variety of jobs which would otherwise require the use of different and expensive equipment.

The HR 130 comes equipped with electronic depth counter, automatic levelling system and air conditioning & heating system in order to better accommodate the operator.

Working Characteristics

Works with Augers & Buckets:

Max diameter	1.300 / 1.600* mm	4.3 / 5.2 ft
Without lower mast extension	1.800 mm	6 ft
Low headroom version depths	19,5 m (working height 7,3 - 8,5 m)	64 ft (working height 24 - 28 ft)
Standard version depths	30 - 40 - 50 m	98.5 - 131 - 164 ft

Works with CFA:

Max diameter	800 mm	2.6 ft
Depths	14 + 5 m	45 + 16.5 ft

Casing Oscillator:

Max. diameter	600 - 1.300 mm	2 - 4.3 ft
---------------	----------------	------------

Diaphragm Walling:

Max size	800 x 2.500 mm	2.6 x 8 ft
Depths	25 m	82 ft

* on request



HR 130

Low headroom version

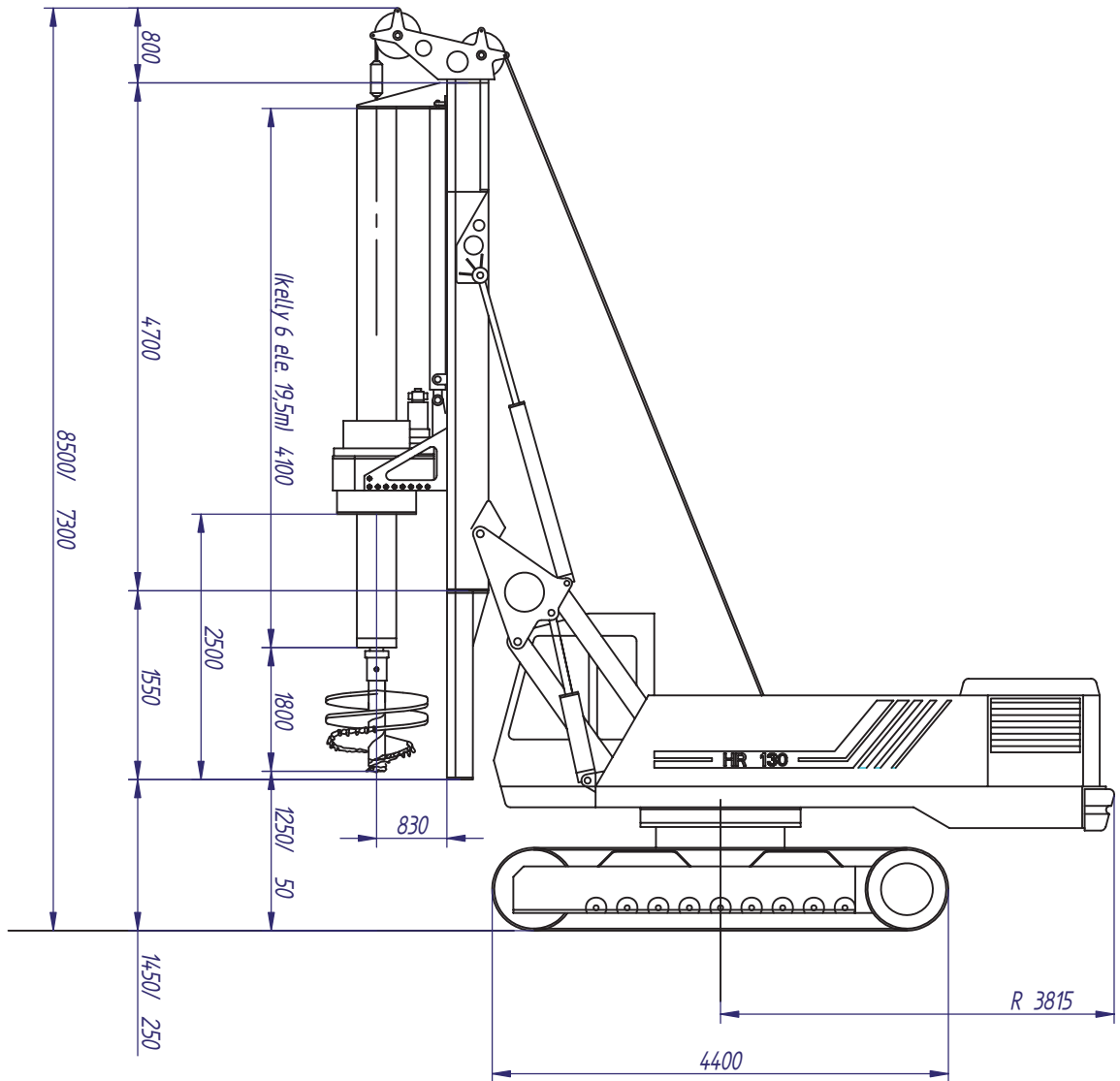

MAIT S.p.A. DRILLING RIGS
 via Flaminia Seconda, 149/153 - P.O. Box 1040 60027 OSIMO (AN) ITALY
 - TEL +39 071 7822186 - FAX +39 071 780535
 - web: <http://www.mait.it> - E-mail: info@mait.it



Technical Data

Rotary:

Nominal torque	170 KNm	125,500 lbsft
Max nominal pulldown	135 KN	30,375 lbs
Max nominal pullback	170 KN	38,250 lbs
Unloading speed	150 rpm	
Rotary stroke	2.500 mm (low headroom version)	8.2 ft (low headroom version)
	4.300 mm (standard version)	14 ft (standard version)

Winches:

Main winch nominal pullback	140 KN	31,500 lbs
Auxiliary winch nominal pullback	80 KN	18,000 lbs

Diesel Engine:

CATERPILLAR C7 ACERT

Power	186 KW	250 HP
Hydraulic oil tank	470 liters	124 gal
Fuel Tank	200 liters	53 gal

Expandable Crawlers:

Length	4.400 mm	14.5 ft
Width	2.540 - 3.640 mm	8.2 ft - 12 ft
Shoes	600 mm	2 ft

Approx. Weight:	32 tons	70,528 lbs
------------------------	---------	------------